

# RPA ultra

OSCILLATION. ROTATION. PROCESS ANALYZATION.

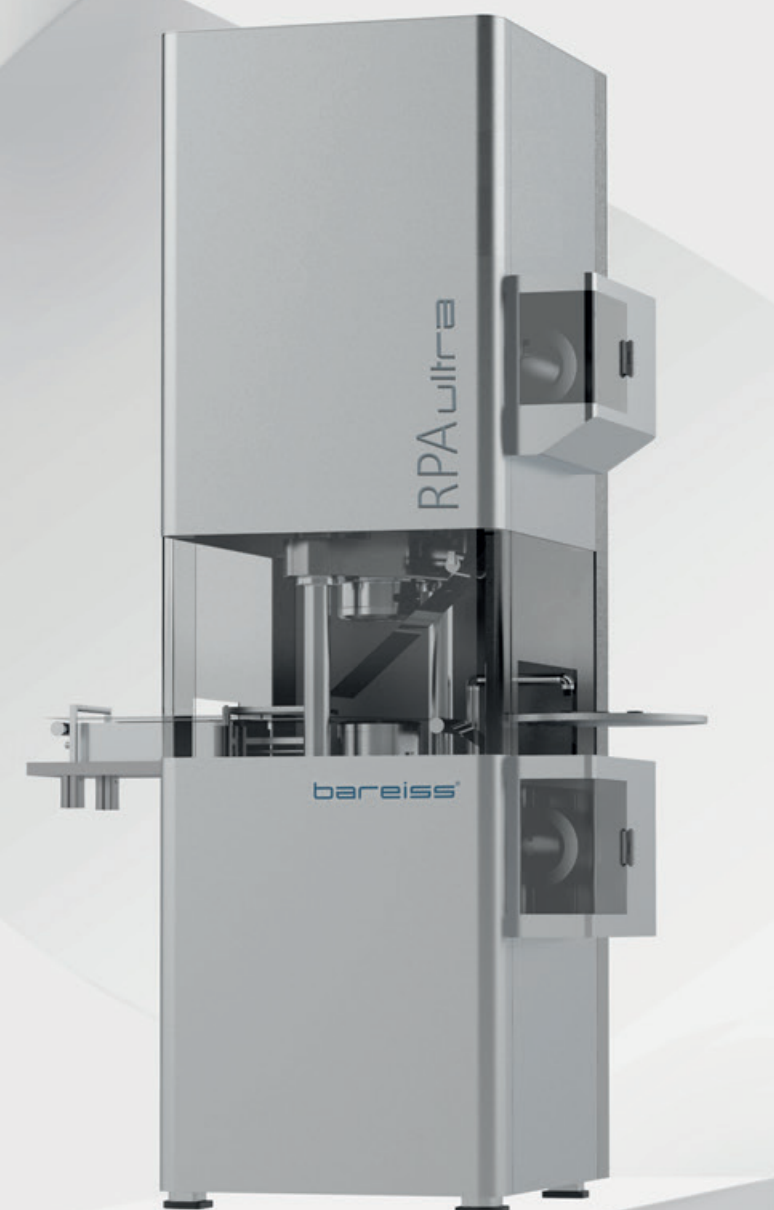

**bareiss**<sup>®</sup>  
PRÜFGERÄTEBAU GMBH



**Always on the move.**

The RPA ultra combines highly dynamic measurement methodology with maximum rigidity.



**Infinite possibilities.**

With a fully rotational lower die, the RPA ultra achieves shear rates at unprecedented levels.



**Down to the smallest detail.**

The high sampling rate of the RPA ultra reveals hidden material characteristics.

**bareiss**<sup>®</sup>  
PRÜFGERÄTEBAU GMBH

*Because we have visions ...*

Highest quality is our drive, customer-oriented solutions are our motivation: that is why we, as a test equipment manufacturer, are expanding our product portfolio and traditionally focus on innovation. With the new RPA ultra, materials can be inspected like never before.

Due to the rotation, it offers completely new possibilities for high shear rates up into the extrusion range. Of course, it also features all other common measuring methods.

This opens a new chapter in elastomer research and answers metrological questions from the past. The RPA ultra is the first "Rubber Process Analyzer" with which it is really possible to analyze processes and completely characterize materials. Starting with polymers, rubber and rubber compounds, it also offers endless possibilities in other areas. We continue to strive to turn our visions into innovations, our plans into reality.

As a test equipment manufacturer with a strong customer focus, it has always been our ambition to fulfill our partners' wishes and respond to their individual needs – worldwide.



*"Listening to customers, understanding problems and generating innovations from them is traditionally our strength."*

Oliver Wirth  
Managing Director and Partner  
Research and Development

*O. Wirth*



# THE FUTURE OF MATERIAL TESTING STARTS NOW.

Supported by:



on the basis of a decision by the German Bundestag

The RPA ultra was developed as part of a cooperation project ZiM (Zentrales Innovationsprogramm Mittelstand) between Bareiss and the Institute for Applied Polymer Chemistry at Aachen University of Applied Sciences.

## STATE OF THE ART

In the version of the RPA used by Monsanto to date, only oscillatory tests with variable frequency and strain can be performed – and thus usually used to determine the complex shear modulus and dynamic viscosity of a material. The classical approach of calculating both the storage modulus and the loss modulus with a simple trigonometric equation only applies to linear viscoelastic behavior.

## THE PROBLEM

Filled rubber compounds, however, show a strongly non-linear rheological behavior (Payne effect) and the measurement signal of unfilled raw rubber becomes nonlinear at higher deformations (LAOS). The issue of compound processability also cannot be quantified to date. As a solution-oriented company, Bareiss has addressed this problem as part of a cooperative project funded by the ZiM and has developed an RPA with extended testing capabilities. This new type of advanced RPA testing allows access to valuable information contained in higher harmonics, steady-state shear viscosity or non-elliptic Lissajous figures.

*“The RPA ultra shifts the quality of testing to an unrivaled level.”*

## THE SOLUTION

The rotational lower die allows the transient viscosity of materials to be determined for the first time in areas that are highly relevant to production. Compared to dynamic viscosity, transient viscosity reflects the realistic processing of rubber compounds. The RPA ultra from Bareiss can certainly perform all test methods of a generic RPA, including isothermal and anisothermal tests, stress relaxation, frequency sweep and amplitude sweep.

*“In the early '90s, Monsanto Instruments aimed to add a continuous rotation mode in their RPA. This failed due to technical limitations of that time. Finally, Bareiss made it a reality in their RPA ultra. This unique test mode provides precise steady shear viscosity, the prerequisite to truly successful flow simulation.”*

Henri G. Burhin,  
Head of Polymer Process Consult SRL



Not only is it capable of performing oscillatory testing over a wider range of frequencies ( $10^{-3}$  Hz to 100 Hz) and strain range (unlimited strain LAOS), but also offers the possibility to perform a continuous shear rate in full rotation from  $10^{-3} \text{ s}^{-1}$  to  $500 \text{ s}^{-1}$ , while standard RPA's can only measure up to a maximum of  $30 \text{ s}^{-1}$ .

*“This groundbreaking technology is different from any RPA on the market.”*

With this type of test, the instrument has successfully measured constant shear viscosity with high repeatability without having to make the corrections required by capillary rheometers, for example. ▶





### THE APPLICATION

This instrument thus expands the range of applications to better describe, among other things, current topics in rubber technology such as wall slip behavior, polymer branching and sustainable fillers (rCB). The number of data points recorded per cycle has increased significantly, which in turn improves the signal-to-noise ratio when performing Fourier Transform Rheology.

The ranges in which the device operates at shear rates of  $500\text{ s}^{-1}$  are typical of the extrusion range. Initial studies have already shown that such a measurement method can be used to make an estimate of the processability of a compound. This means that in the event of substitution or fluctuations in raw material quality, the user can recognize at a very early stage whether this compound can be processed well or whether further processing aids need to be added – this also offers crucial time saving and financial advantages in the new development of rubber compounds.

*“Bareiss’ RPA ultra is the first real major advancement in RPA’s since the 80’s”*

Thomas Rauschmann  
Consulting  
RTS Rubber Technology and Service

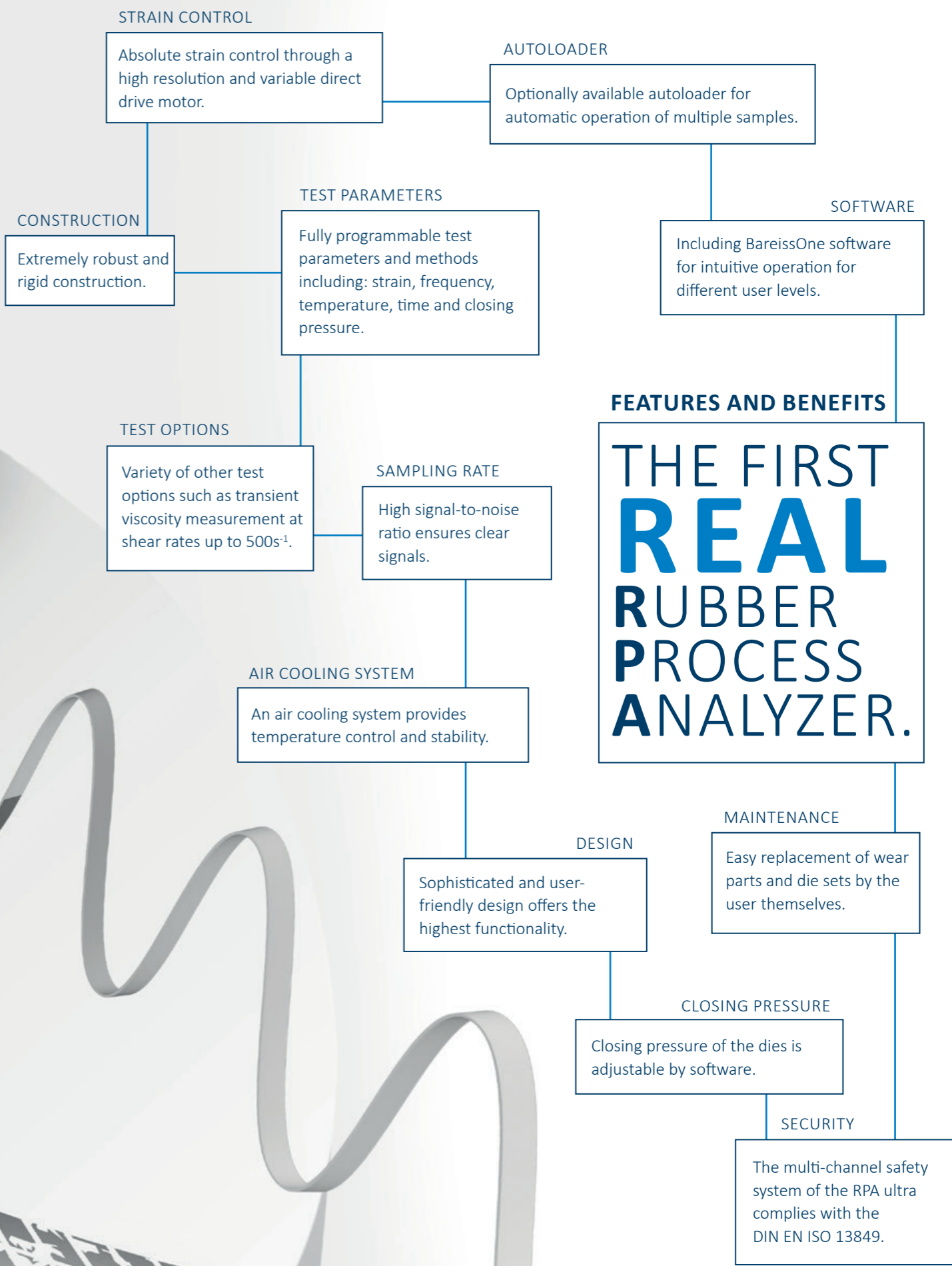
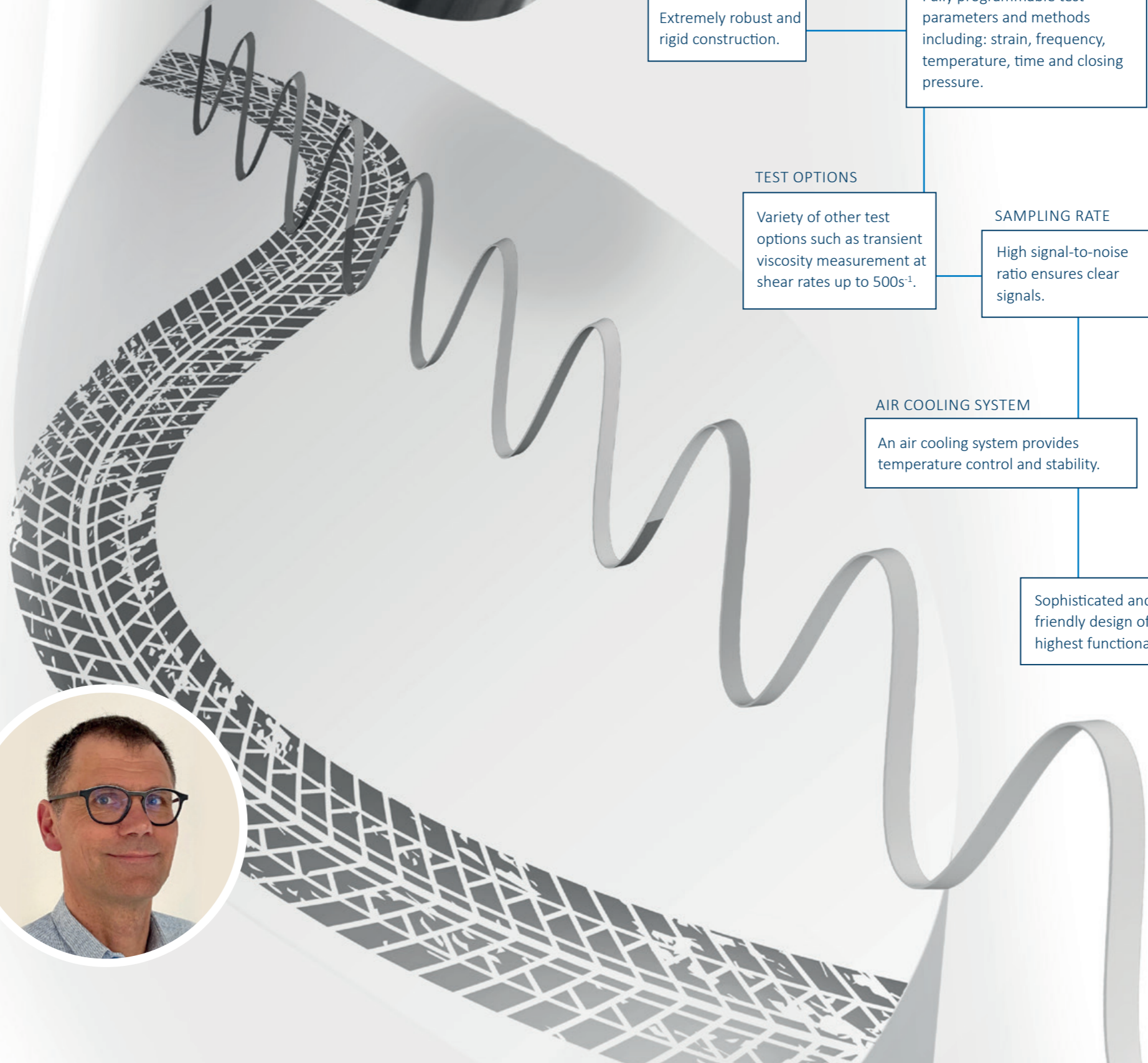
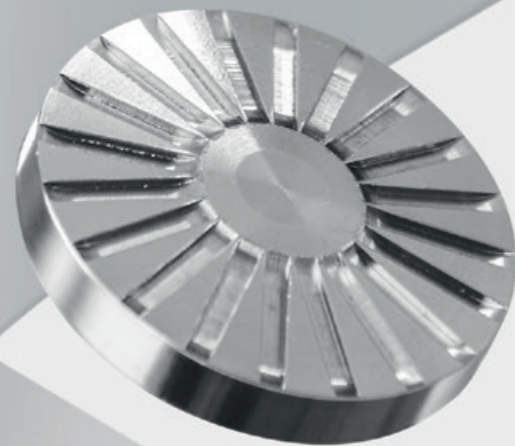

# RPA ultra

For an optimal signal-to-noise ratio during a measurement, the number of data points is of great importance.

The RPA ultra meets all requirements here: high sampling rate and instrument stiffness, state-of-the-art electronics and an optimized Fourier algorithm delivers unique results for material characterization.

The Fourier spectrum of the torque (modulus) and strain (displacement) is always analyzed and displayed; only then can material differences be made transparent in a repeatable manner.

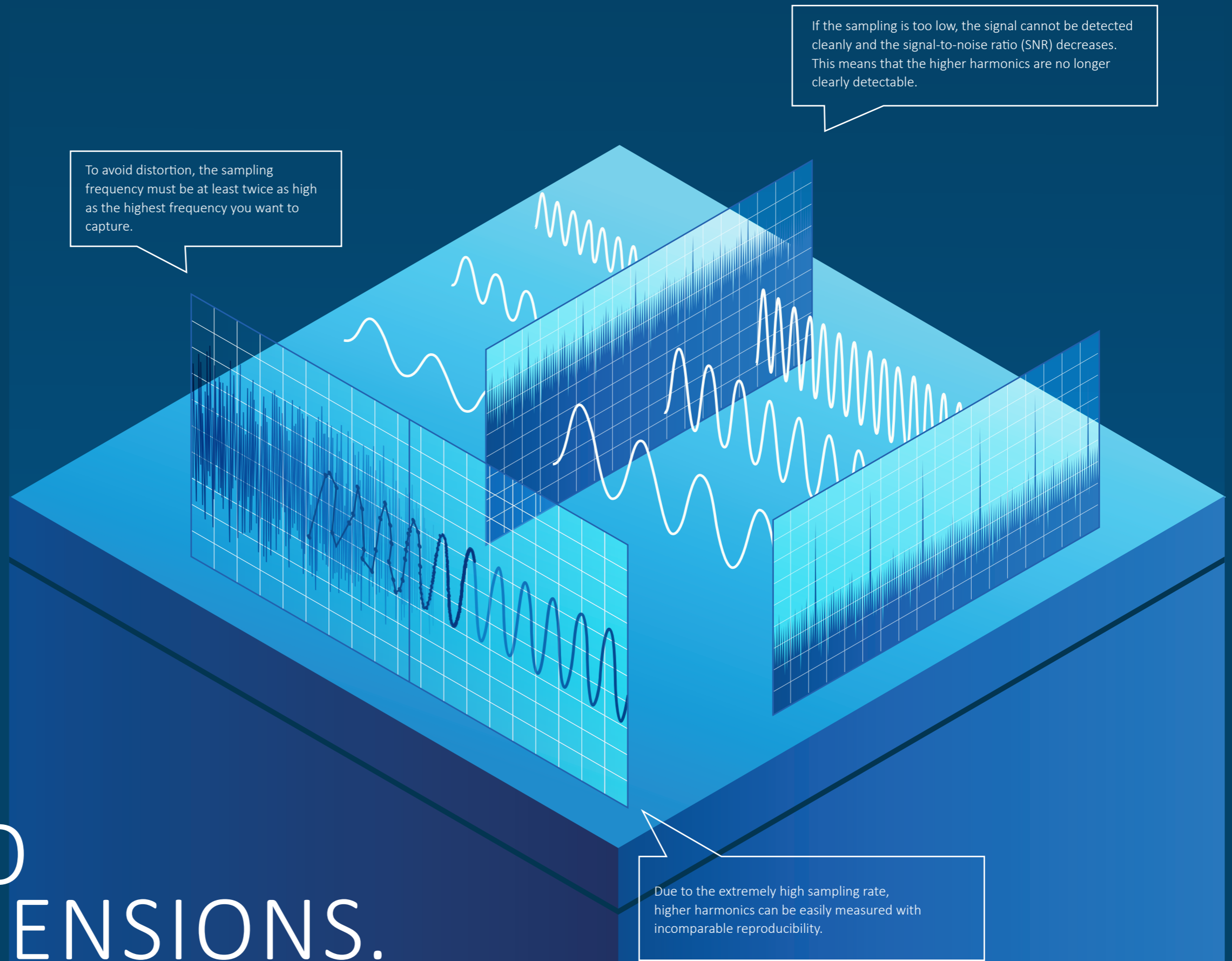

# DIVE INTO NEW DIMENSIONS.

FOURIER TRANSFORM RHEOLOGY

# RPA<sub>Ultra</sub> MEASURING METHODS AND THEIR APPLICATION.

## Steady Shear Viscosity

To better understand the **manufacturing process** of an unvulcanized rubber compound, the steady shear viscosity is one of the most important properties, especially crucial for determining the process parameters for extrusion and injection molding purposes.

The RPA ultra's rotating lower die with unlimited strain thus provides the user with a dual test mode: dynamic and steady shear.

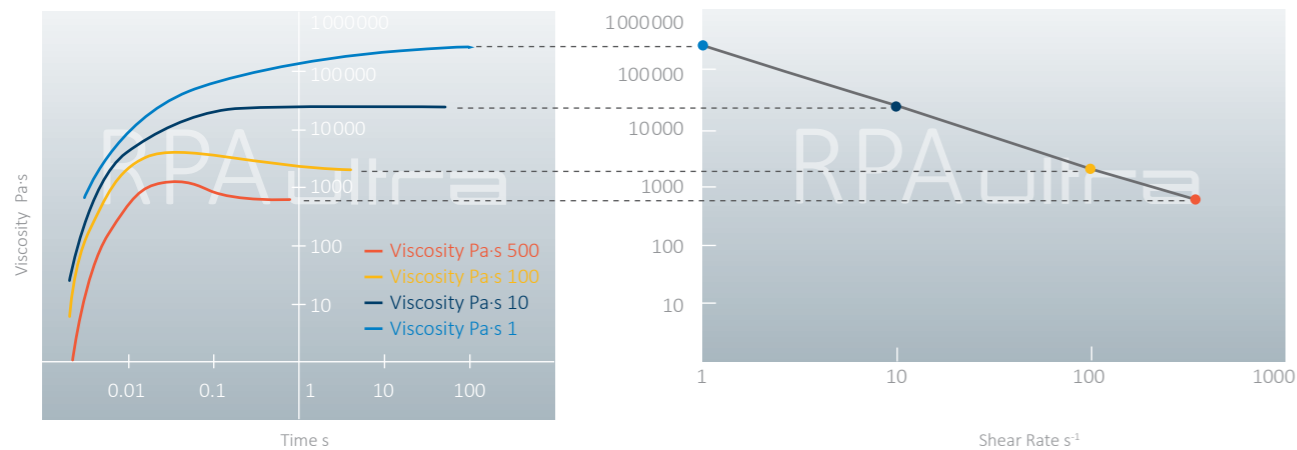

## Wall Slip

A significant challenge in the **processing of rubber compounds** is the issue of Wall Slip.

This is a rheological phenomenon where slippage occurs, for example, between the extruder wall and the flowing material. We offer an optional solution where the upper die is replaced by a defined polished die set. In combination with a programmable internal pressure, this allows Wall Slip experiments to be carried out.

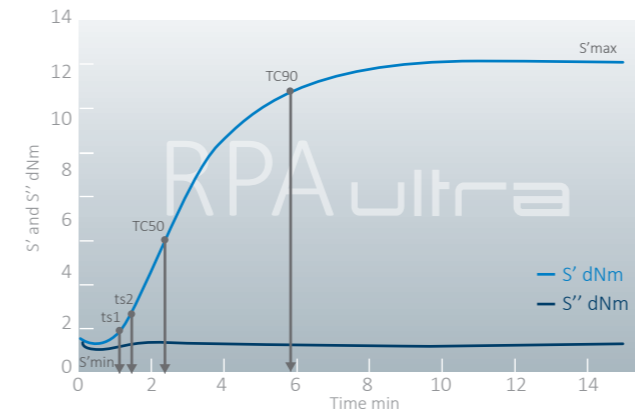
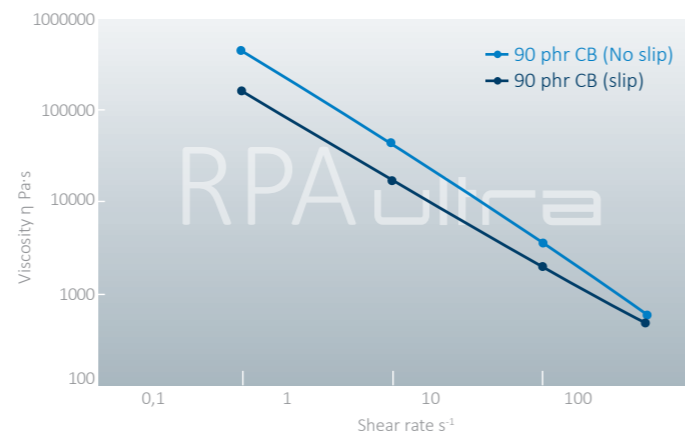

## Isothermal Test

One of the most common and important tests performed on rubber compounds are the isothermal **cure tests**.

All important test parameters such as maximum and minimum torque, TC values, reaction time and rate, etc. are determined and made available to the user in tabular and/or graphical form for further analysis in the BareissOne software.

## Non-Isothermal Test

In order to evaluate the behavior of a sample over a **wide temperature range**, non-isothermal measurements (temperature sweep) are typically performed at different heating rates.

This measurement at different heating rates also paves the way for **non-isothermal kinetic calculations** – a module that is also integrated into the BareissOne software.

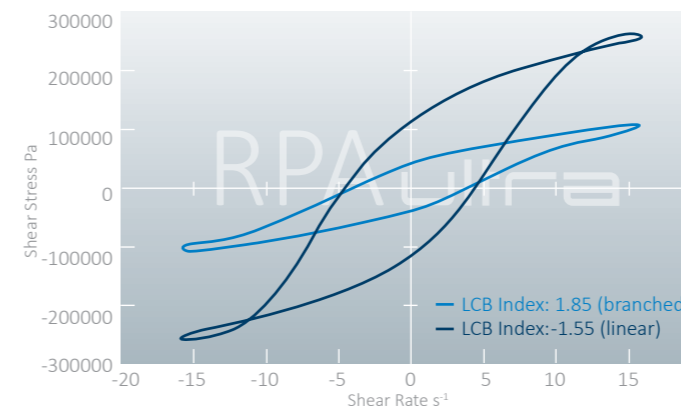
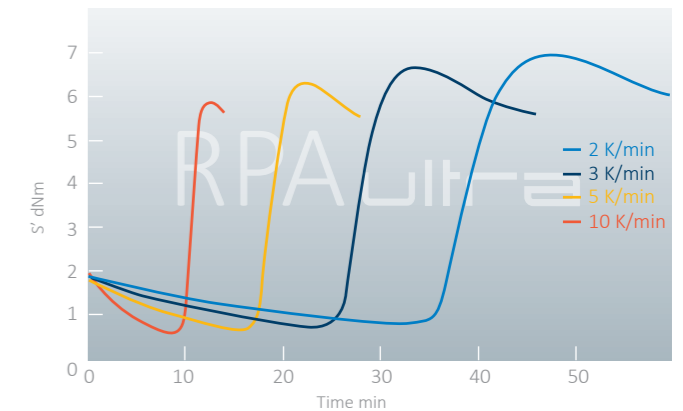

## Large Amplitude Oscillatory Shear (LAOS)

LAOS is essentially a strain sweep performed at relatively **large amplitudes** to investigate and evaluate the nonlinear viscoelastic behavior of a sample.

The nonlinear behavior of a material is based on its polymer architecture > linear or branched polymer. The LAOS results are also used for **FT-Rheology**. The calculation of the **LCB index** (Long Chain Branching) or the **Q parameter** is performed using the harmonic spectrum from Fourier analysis (FFT).

PHONE: +49 7305 / 96 42-10  
service@bareiss.de



WE ARE YOUR  
COMPETENT PARTNER.

For further information and advice on rheology, measurement methods and individual requirements, please contact our application team.

### Kinetics

From an isothermal test, values such as incubation time, reaction order and conversion rate constant can be determined for each temperature. The calculation is according to the DIN 53529 standard. With the help of the incubation time and the conversion rate constant at at least 3 different temperatures,

the activation energies of the incubation and the conversion can also be determined. These are essential parameters for the **computation of the heating time** for the test specimen and also finds its use in production line.

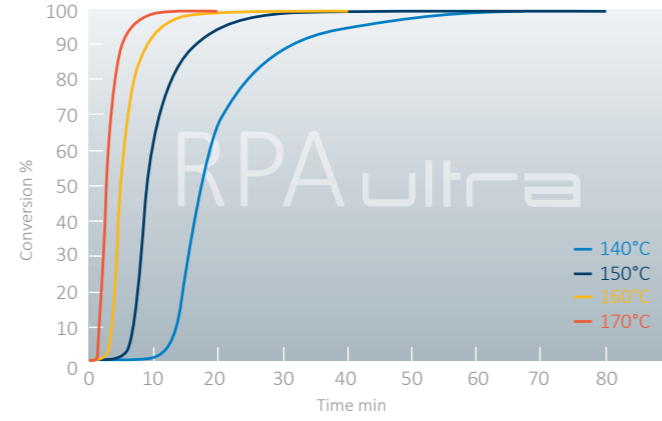
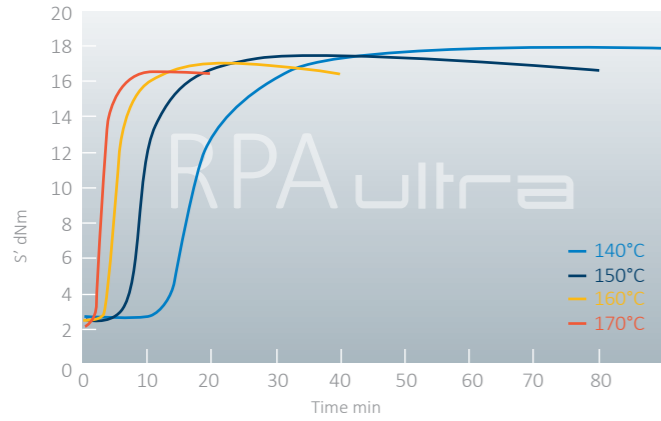

### Frequency Sweep

By characterizing a sample over a wide range of frequencies, the user obtains a comprehensive overview of the viscoelastic behavior as well as the molecular structure (**molecular weight and molecular weight distribution**).

Viscoelastic properties such as complex modulus, elastic modulus, loss modulus, complex viscosity, phase angle, etc. are calculated at each frequency as a result of the frequency-dependent behavior of the sample.

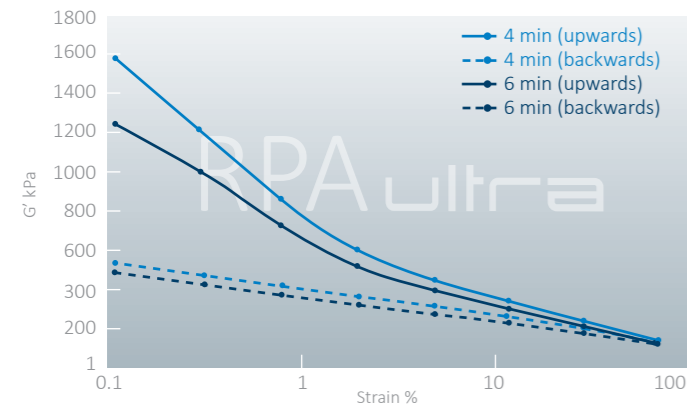
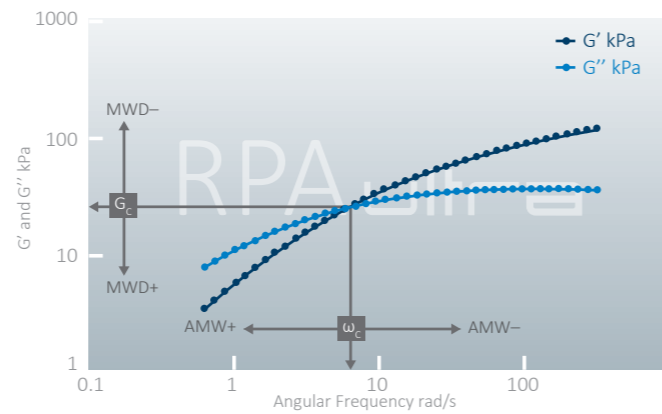

### Strain Sweep

Measuring a specimen over a wide strain range shows the **strain-dependent behavior**, e.g., the linear viscoelastic range (LVE) up to Large Amplitude Oscillatory Shear (LAOS).

The Payne test, which is performed at small strain amplitudes to investigate the (filler/polymer) filler networks, reveals information about the **filler content** and the **filler dispersion levels**.

### Matrix test

In the frequency and strain sweeps described above, one parameter (frequency or strain) is held constant while the other parameter (frequency or strain) is changed over a range.

Matrix testing allows the user to change both parameters – frequency and strain – during a sweep, making the **test method more flexible** and thus providing **more information with a single measurement**.

# SPECIFICATIONS

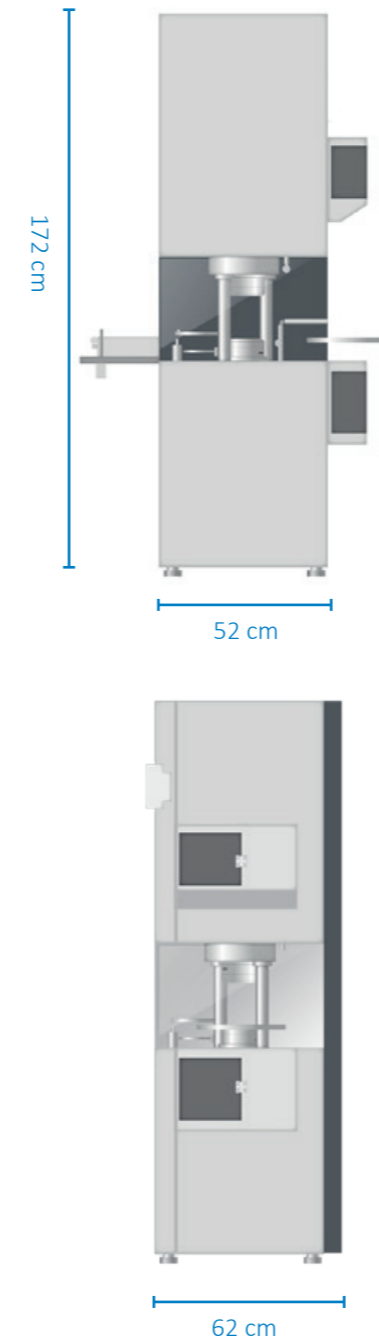

<b>Max. shear rate in rotation</b>	500 s <sup>-1</sup>
<b>Max. shear rate in oscillation</b>	100 s <sup>-1</sup>
<b>Max. heating rate</b>	1.33°C/s (80°C/min)
<b>Max. cooling rate</b>	0.5°C/s
<b>Die config.</b>	Sealed die, biconical and plate-plate
<b>Drive system</b>	High dynamic torque motor, High resolution controller
<b>Oscillation frequency</b>	0.001 to 100 Hz
<b>Oscillation strain</b>	+/- 0.001° to unlimited, +/- 0.014% to unlimited > rotational
<b>Temperature range</b>	Ambient to 235°C
<b>Measured data</b>	Torque, temperature, frequency, strain; Optional: Normal force, die pressure
<b>Die gap</b>	0.48 mm nominal
<b>Sample volume</b>	4.5 cm <sup>3</sup>
<b>Electrical</b>	400V/16A
<b>Closing system</b>	Soft closing to prevent foil rips and damage of test samples; optionally variable closing force.
<b>Torque range</b>	0.001 to 250 dNm
<b>Normal force / Pressure (opt.):</b>	up to 10 kN
<b>Test modes</b>	Isothermal, Non-Isothermal, Strain Sweep, Frequency Sweep, Steady Shear, Relaxation, LAOS, Matrix Test
<b>Interface</b>	Ethernet
<b>Data points</b>	Over 3500 data points available for each static subtest including S' Min, S' Max, TS 1, TS 2, TC 10, TC 30, TC 50, TC 90 Integrated, automatic reporting features for dynamic tests
<b>Pneumatics</b>	min. 4.5 Bar (11.5 kN) / 60 psi

**Measurements**  
W x D x H: 52 x 62 x 172 cm

**Weight** approx. 350 kg

# ACCESSORIES

## Wallslip Die Set

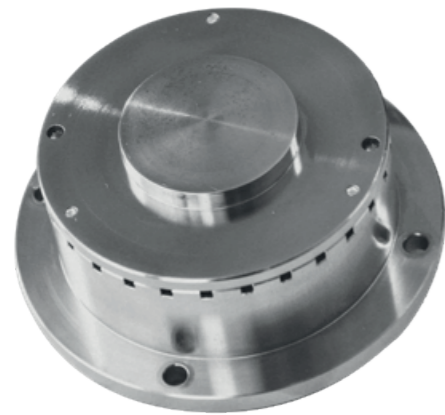

Optionally available die set with defined polished surface to investigate wall slip effect on rubber compounds. For complete measurement of the effect, the die set must be exchanged during the measurement.

For further information on the test method and application, please contact the application team at Bareiss.



### Seal

Replacement seals for upper and lower dies of your MDR or RPA.



### Heat resistant gloves

You may want to protect your hands with a pair of these gloves while operating a rheology instrument.

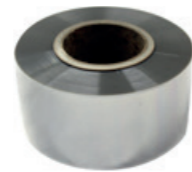

### Melinex film roll

Melinex is a well-known brand for polyester film used in rubber and polymer industry. At 600 mm in length and 80 mm in width, a single roll can last for as many tests as possible.



### Dartek film roll

Use this Dartek nylon film to protect dies from contamination. Ideal for RPA/CCR high strain testing.



### Die groove pick

Use a die groove pick to remove any stubborn material residues.



### Tweezers

A handy tool for picking up samples from the die.



### Cleaning brush

For a smooth operation and a good test outcome, it is important to remove any material debris left on the dies with a wire-bristle brush.

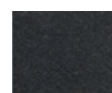

### Fan filters

Replacement filters.

# SOFTWARE

## BareissOne

BareissOne is a modularized software that is aimed to provide a common platform with integration of different test categories.

Whether it is a standard test for one single measurement or a series of tests that requires a complex test sequence editing, BareissOne is designed to offer all levels of user's demands.

Features such as user authorization, system log, project management, version control and custom report are all at your fingertips.

BareissOne has made software use easier than it ever was before.

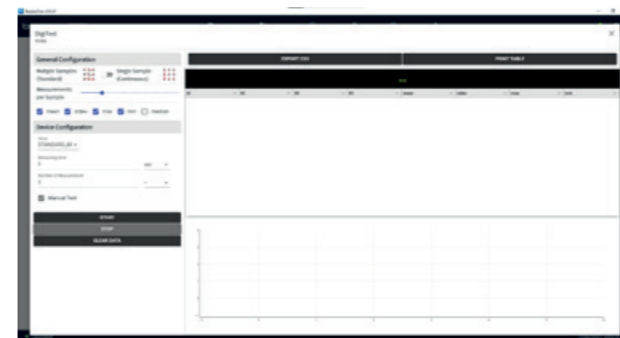

With its easy-to-understand icons and workflows, familiarizing yourself with the BareissOne software is only a matter of a few hours of training. Whether you are a new or experienced user, everyone can quickly start testing at the touch of a few clicks.

The new display layout gives the users a comprehensive view of the test workspace, identification of the test category and the available software functions.



# QUALITY AND SERVICE

*from one source*



**ISO 17025**

ACCREDITED LABORATORY



*„For many of our customers, we are not just a supplier, but a valued partner and consultant, on everything related to hardness testing – I am proud of that!“*

Katrin Shen  
Managing Director and Partner  
Head of Sales and Marketing



## LEASING

Regardless of your undertakings, leasing enables you to equip yourself optimally, without tying up capital unnecessarily.

## DEMONSTRATION

We would be pleased to present our products exclusively online or on-site and advise you on your individual requirements.

## COMMISSIONED MEASUREMENTS WITH PROTOCOL

If you haven't used a test facility until now but you still need test reports, you can send the samples directly to Bareiss for commissioned measurement. After consultation, we undertake the sample preparation and choose an adequate method. You will receive your samples back in a timely manner, documented with the recorded measurement results.

## COMMISSIONED MEASUREMENT UNDER THE INFLUENCE OF TEMPERATURE

In our digi Chamber we undertake commissioned measurements for you, with temperatures ranging between -40°C and +180°C. Heating is also available for Abrasion Testing.

## TRAINING

We regularly offer training courses on the subject of hardness testing on rubber and plastics. We focus on your samples, verifying them in accordance with current standards. For the theoretical part, we introduce you to the basics, going into detail on the Shore and IRDH, as well as VLRH procedures.

For the duration of the service work on your testing devices or to bridge short-term bottlenecks in your company, we are pleased to provide you with a suitable rental device.

## ON-SITE CALIBRATION

The Bareiss onsite calibration service is provided throughout Europe. In addition to that, we have one satellite calibration laboratory in North America and two others in Asia Pacific.

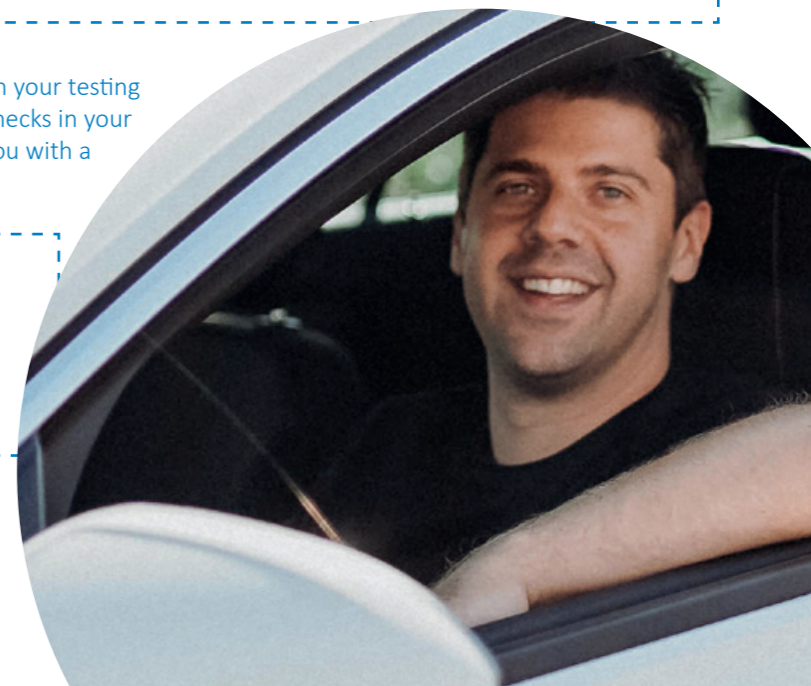

 If you have any further questions, please do not hesitate to contact us!



## HPE III | HPE III Basic

- ASTM D2240
- DIN EN ISO 868
- DIN ISO 48-4

Digital premium handheld hardness tester for the Shore hardness measurement with illuminated display, sensors for the recording of environmental conditions and integrated compression sleeve for vertical support and standard contact pressure.

- For all Shore variants
- Parameters for humidity and temperature (limited to Shore A and D)
- Traceable measurements
- Patented hand grip for applying full and constant load
- Various test stands available



**MOST FLEXIBLE HARDNESS TESTER WORLDWIDE**

## digi test II

- ASTM D2240
- ASTM D1415
- DIN EN ISO 868
- DIN ISO 48-2
- DIN ISO 48-3
- DIN ISO 48-4
- NFT 46-003
- TD 0000 2001
- TD 0000 2002

Modular digital measuring device for fully-automated hardness tests, according to Shore, VLRH and IRHD on polymers with variable test geometries.

- For all Shore and IRHD variants
- Easy assembly and disassembly
- Interchangeable measuring units (less than 10 seconds)
- A complete build to suit system
- In connection with the Electronic Unit for data analysis, archive and clear value reading
- Various centering devices available

**PIONEERING WITH**  
*Enthusiasm*

We help you understand your material! With innovation and progress, Bareiss has been shaping the development of hardness testing on elastomers and other soft elastic materials since the company was founded in 1954. Today, as in the past, we develop and manufacture high-quality testing equipment for hardness measurement on rubber, plastics and soft elastic materials in the pharmaceutical and food industries- and sell them worldwide.



## HDA 120

- ASTM D2240
- ASTM D792
- DIN EN ISO 868
- DIN EN ISO 1183-1
- DIN ISO 48-2
- DIN ISO 48-4
- ISO 2781

Combined hardness-density machine with PLC and touchscreen to determine the hardness and density of flat test specimens made of rubber-elastic, non-cellular plastics, elastomers and other rubber products.

- Automated determination of hardness and density, with up to 20 samples per round
- Programmable number of wet weighing processes
- Multiple measurements to reduce measurement inaccuracies
- Optional good-bad specimen sorting
- Tested safety technology to protect operator and process

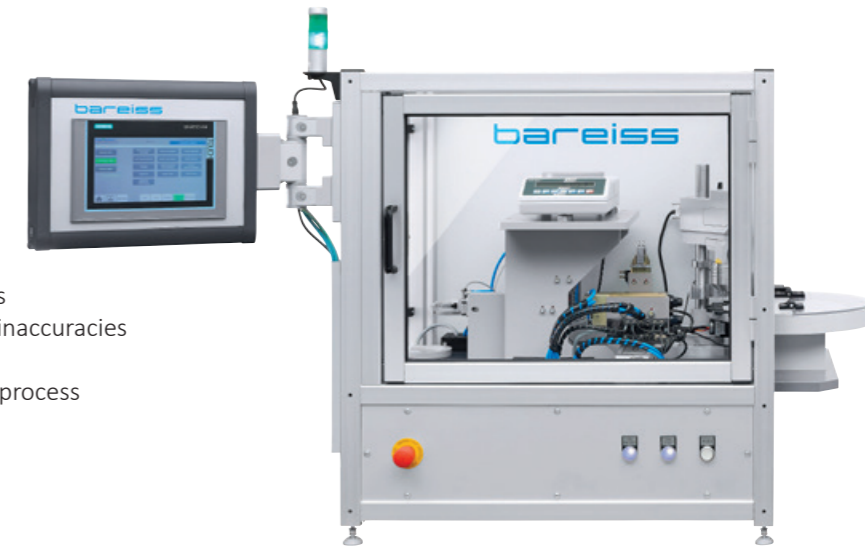

## digiChamber

- ASTM D2240
- ASTM D1415
- DIN ISO 48-2
- DIN ISO 48-4

High-quality temperature control or climatic chamber in conjunction with the proven hardness tester digi test II, rotation table and software with database function, for serial testing of the hardness of polymers according to Shore A, D or IRHD N, depending on the temperature.

- Automatic or manual positioning of the specimens
- External electronic unit including software "digiCenter" with database function
- Control of temperature, relative humidity, measuring rhythm, number of measuring points and measuring time
- Output of measured values and temperature curve as graph or table
- Programming of temperature and humidity progression, Heating rate and dwell time
- Different centering devices available
- Integrated PC and display for intuitive control and analysis of the measured values

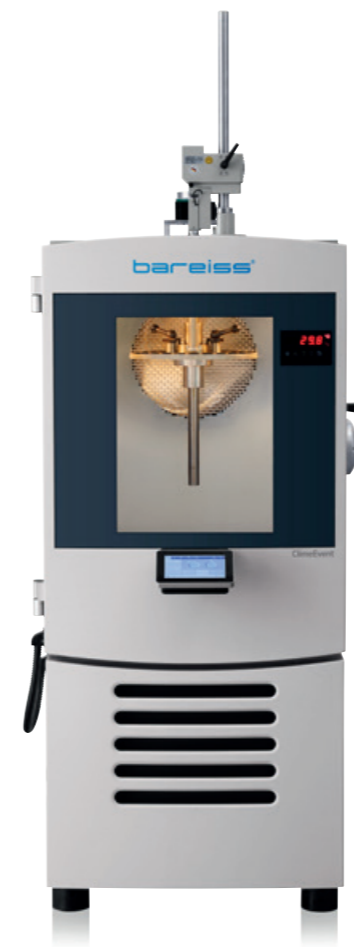

## Rebound resilience tester

- ASTM D7121
- DIN 53512
- ISO 4662

Fully-automatic digital measuring device with guided pendulum hammer, external electronic unit and optional temperature control module for the determination of rebound resilience on elastomers.

- Guided pendulum movement
- Automatic sample detection protects against idling and damage to the anvil plate
- Flexible spring clamp system for various specimen thicknesses, with up to 50 mm specimen thickness.
- Optional: 200N clamping device





**Bareiss  
Prüfgerätebau GmbH**  
Germany

[sales@bareiss.de](mailto:sales@bareiss.de)  
[www.bareiss.de](http://www.bareiss.de)

**Bareiss Shanghai  
Limited**  
China

[central@bareiss.cn](mailto:central@bareiss.cn)  
[www.bareiss.cn](http://www.bareiss.cn)

**Bareiss North America  
Inc.**  
Canada

[info@bareiss-testing.com](mailto:info@bareiss-testing.com)  
[www.bareiss-testing.com](http://www.bareiss-testing.com)

**Bareiss Taiwan  
Technology Co., Ltd.**  
Asia

[central@bareiss.tw](mailto:central@bareiss.tw)  
[www.bareiss.tw](http://www.bareiss.tw)

**MADE IN GERMANY SINCE 1954.**

Supported by:



Federal Ministry  
for Economic Affairs  
and Climate Action

on the basis of a decision  
by the German Bundestag



**DKD**



Deutsche  
Akkreditierungsstelle  
D-K-15206-01-00

The accreditation is valid for the scope listed in certificate  
D-K-15206-01-00 (mechanical measurands in the range of hardness).